

Made in America

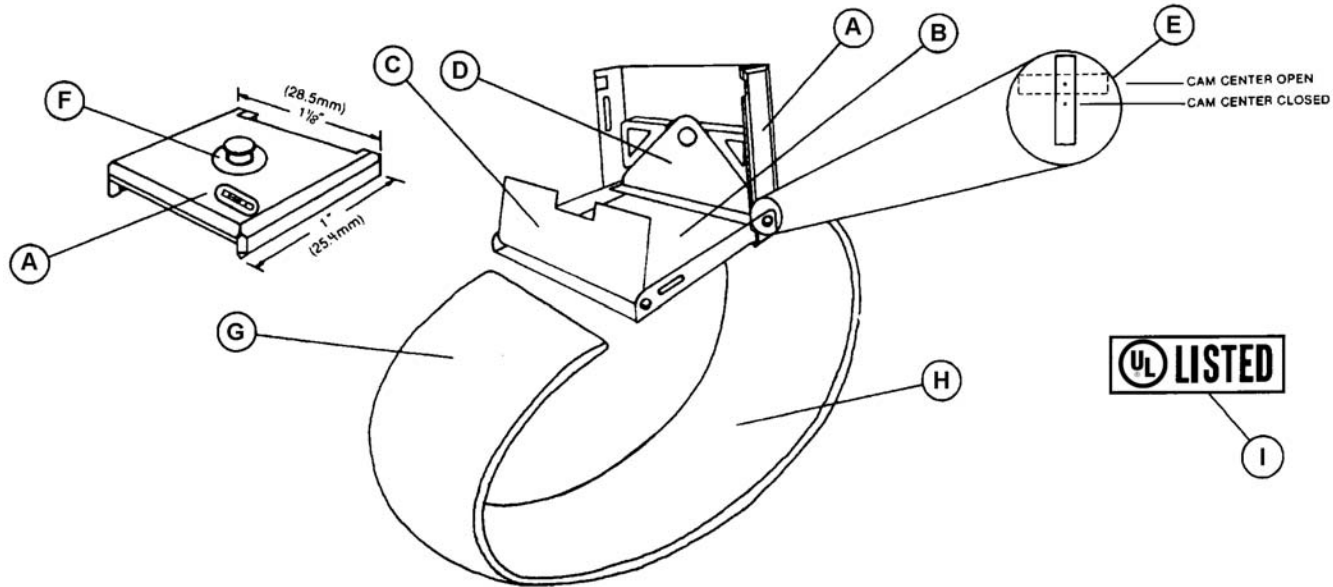

- A. Insulating cap, blue ABS plastic.
 - B. 300 series stainless steel backplate (0.016" thick). Manufacturing date code is stamped into stainless steel backplate.
 - C. Small cam lock, allows material replacement. 300 series stainless steel.
 - D. Large cam lock, allows size adjustment, maintains electrical continuity even when open. 300 series stainless steel.
 - E. Patented* floating cam lock allows wide opening for easy adjustment and secures material down against base plate when closed.
 - F. 4mm snap stud machined from 300 series stainless steel. Fits to 4mm spring loaded medical type socket. Coil cord disengages from snap with 1-5 lbs. of perpendicular force, fulfilling ESD-S1 paragraph 4.1.6 breakaway force requirement. Durable, providing long life well beyond that of sheet metal snaps.
 - G. Knit elastic band material of light blue fiber; .875" (22mm) wide and 0.10" (2.5mm) thick. 50 strands of textured polyester, 36 strands of lycra spandex and 14 strands of silver plated polypropylene yarn. Made with pure silver irreversibly bound to fibers providing both antimicrobial and anti-odor properties. Outer surface of light blue fibers act as an insulator.
 - H. The conductive silver plated polypropylene (see G) represents 13.5% of the material by weight. The 14 strands of conductive polypropylene are randomly knit on the inner surface of the material and are electrically isolated from the outer surface (blue side).
 - I. Underwriters Laboratory listing 90P1C.
- Meets or exceeds requirements of ANSI ESD-S20.20 and EOS/ESD-S1-1987.

ITEM	DESCRIPTION	CIRCUMFERENCE		WIDTH
		MIN	MAX	
09028	Band Only	2.5" (63.5mm)	13" (330mm)	.875" (22mm)
09069	Band w/12' Black Cord	2.5" (63.5mm)	13" (330mm)	.875" (22mm)
09070	Band w/6' Black Cord	2.5" (63.5mm)	13" (330mm)	.875" (22mm)
09071	Band w/6' Beige Cord	2.5" (63.5mm)	13" (330mm)	.875" (22mm)
09072	Band w/12' Beige Cord	2.5" (63.5mm)	13" (330mm)	.875" (22mm)
09029	Replacement Strip	2.5" (63.5mm)	13" (330mm)	.875" (22mm)

*U.S. Patent No. 4,662,695

WRISTBAND, ELASTIC, ADJUSTABLE

DESCO

DESCO WEST: 3651 WALNUT AVE., CHINO, CA 91710 WEB SITE: www.desco.com
 PHONE (909) 627-8178 FAX (909) 627-7449
 DESCO EAST: 90 HUDSON RD, CANTON, MA 02021-1407
 PHONE (781) 821-8370 FAX (781) 575-0172

DRAWING NUMBER
09028

DATE:
July
2008